

HX10E 1150X540

LIFTING STABILITY



HX10

The HX10 series, which is available in both a manual and an electric version, allows for easy and light lifting to a height of 800 mm, thus becoming a practical work platform, which is suitable for places such as machine workshops. This pallet truck is also able to carry out the support function and material supply along the assembly and production lines.

CONTROL LEVER

The redesigned hydraulic unit allows for less effort at the steering wheel for all loads and a quick elevated function (30 cycles) for loads up to 150 kg.



EMERGENCY PUSHBUTTON

The emergency pushbutton with a battery cut-off (isolator) switch function and an off-load valve allows for a smoother lowering of the load; these are some of the devices that make the work safer and more efficient.



FRONT AND REAR STABILISERS

The new control linkage makes the entry onto the closed side of the pallet possible by slight lifting, which facilitates the successive handling phases. Furthermore, more machine stability has been obtained using load rollers in a more advanced position and by providing front stabilisers as a standard.

Rear stabilizers, in turn, render work stable and safe even in the case of elevated loads once the 400 mm of lifting up have been exceeded.



PHOTO AUTO LEVELING SYSTEM

- An automatic system which, by means of a photocell, adjusts the height of the forks, thus maintaining the work height set.
- An optical and acoustic signal is activated at every fork movement.
- Possibility of adjusting the photocell both in height and reading angle.
- Micro-switch, active both on the way up to prevent superfluous absorption of energy and on the way down to protect the operator.



Descriere

1.1 Producător	LIFTER		
1.3 Comandă	Manual		
1.4 Poziție operare	Pedestru		
1.5 Capacitate maximă	Q	Kg	1000
1.6 Distanța la centrul de aplicare al sarcinii	c	mm	600
1.8 Sarcina de la osie la capătul furcilor	x	mm	993
1.9 Ampatament	y	mm	1231

Greutăți

2.1 Greutate de operare (acumulator inclus)	Kg	139
2.2 Sarcină osie, încărcare pe spate	Kg	706
2.2 Sarcină osie, încărcare pe față	Kg	433
2.3 Sarcină osie, liber față	Kg	112
2.3 Sarcină osie, liber spate	Kg	27

Cauciucuri/Șasiuri

3.1 Cauciucuri: roți direcție	RUBBER	
3.1 Cauciucuri: transportoare cu role	POLY.I.	
3.2 Mărime cauciuc: roți direcție - Lățime	mm	50
3.2 Mărime cauciuc: roți direcție - Diametru	mm	200
3.3 Mărime cauciuc: transportoare cu role - Diametru	mm	80
3.3 Mărime cauciuc: transportoare cu role - Lățime	mm	50
3.5 Dimensiune cauciuc: roti spate	nr	2
3.6 Ecartament, față	b10 mm	155
3.7 Ecartament, spate	b11 mm	447

Dimensiuni

4.4 Înălțime stivuitor	h3 mm	715
4.9 Înălțime manetă în poziția de deplasare, max	h14 mm	1300
4.9 Height of tiller in drive position min	h14 mm	915
4.15 Înălțime, coborât	h13 mm	85
4.19 Lungime globală	l1 mm	1690
4.20 Distanța până la suprafața frontală a furcilor	l2 mm	540
4.21 Lățime globală	b1 mm	540
4.22 Dimensiuni furcă - grosime	s mm	48
4.22 Dimensiuni furcă - Lățime	e mm	160
4.22 Dimensiuni furcă - Lungime	l mm	1150
4.25 Distanța între furci	b5 mm	540
4.32 Gardă la sol și mijloc ampatament	m2 mm	21
4.34 Lățime culoar	Ast mm	2193
4.35 Rază de virare	Wa mm	1541

Performante

5.2 Viteză de ridicare, încărcat	m/s	0.08
5.2 Viteză de ridicare, descărcat	m/s	0.13
5.3 Viteză de coborâre, încărcat	m/s	0.13
5.3 Viteză de coborâre, descărcat	m/s	0.06

Motoare electrice

6.2 Putere motor stivuitor	kW	1.6
Tip acumulator	Type	Automobil (C20)
6.4 Tensiune acumulator	V	12
6.4 Capacitate acumulator, Min	Ah	60
6.4 Capacitate acumulator, Max	Ah	60
6.5 Greutate acumulator, min	Kg	14
6.5 Greutate acumulator, max	Kg	14

*Battery and external battery charger
Also available in GEL version and with an integrated battery charger

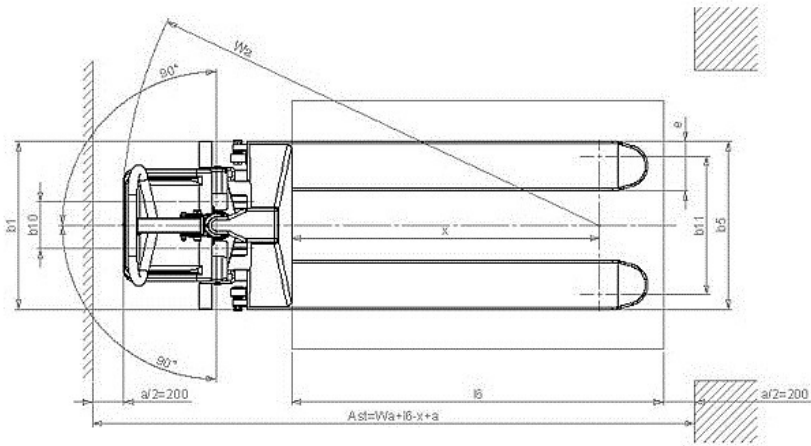
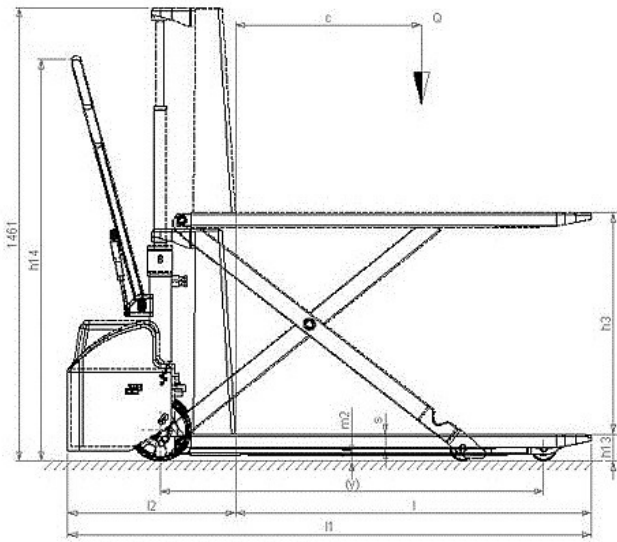

The information is aligned with the Data file at the time of download. Printed on 01/10/2017 (ID 481)

©2017 | PR INDUSTRIAL s.r.l. | All rights reserved | Image shown may not reflect actual package.
Specifications subject to change without notice

