

I-TON S4 1150X520

LIGHT, SILENT, EASILY, MANOEVRABLE,
INNOVATIVE



MATERIALS INNOVATION & RESEARCH

I-ton: is the only pallet truck in the world made of non-metallic material. This new techno-polymer compound, based on modern technologies, is highly rigid, robust as steel, the conventional used material and offers some important benefits:

- It is light
- It doesn't deform permanently
- It can be used in a broad temperature range
- It preserves its surface characteristics even when it is exposed to external corrosion agents.

ERGONOMIC FOR PEOPLE

I-ton is light, quiet and has great manoeuvrability, making easier operator worklife, even for non professional users.

ERGONOMIC FOR HANDLING GOODS

I-ton guarantees quality and efficiency, assuring no corrosion, no rust and no contamination.

ERGONOMIC FOR WORK

It is the hand pallet truck fitting to the widest range of applications, easy to be used by all the operators, guaranteeing a valuable improvement of productivity.

ERGONOMIC FOR THE ENVIRONMENT

The material used for I-ton and the productive process guarantee fewer CO₂ emissions during its life cycle, at the end of which it can be easily disassembled and recycled.

I-TON INOX OR GALVANIZED VERSION

Stainless steel or galvanized components replace the carbon steel ones of the standard version, also lubricants suitable for food contact and low temperature oils are used, making I-ton the ideal solution to operate in clean environments, where hygiene and extreme corrosion resistance are of the utmost importance.

Descriere

1.1 Producător			LIFTER
1.3 Comandă			Manual
1.4 Poziție operare			Pedestru
1.5 Capacitate maximă	Q	Kg	1000
1.6 Distanța la centrul de aplicare al sarcinii	c	mm	600
1.8 Sarcina de la osie la capătul furcilor	x	mm	925
1.9 Ampatament	y	mm	1182

Greutăți

2.1 Greutate de operare		Kg	38
2.2 Sarcină osie, încărcare pe spate		Kg	738
2.2 Sarcină osie, încărcare pe față		Kg	300
2.3 Sarcină osie, liber față		Kg	25
2.3 Sarcină osie, liber spate		Kg	13

Cauciucuri/Șasiuri

3.1 Cauciucuri: roți direcție			POLY.I./ NYLON
3.1 Cauciucuri: transportoare cu role			POLY.I.
3.2 Mărime cauciuc: roți direcție - Diametru		mm	180
3.2 Mărime cauciuc: roți direcție - Lățime		mm	40
3.3 Mărime cauciuc: transportoare cu role - Diametru		mm	60
3.3 Mărime cauciuc: transportoare cu role - Lățime		mm	60
3.5 Dimensiune cauciuc: roti spate		nr	4
3.5 Ax de echilibru spate			No
3.6 Ecartament, față	b10	mm	160
3.7 Ecartament, spate	b11	mm	365

Dimensiuni

4.4 Înălțime stivuitor	h3	mm	115
4.9 Înălțime manetă în poziția de deplasare, max	h14	mm	1175
4.15 Înălțime, coborât	h13	mm	85
4.19 Lungime globală	l1	mm	1575
4.20 Distanța până la suprafața frontală a furcilor	l2	mm	425
4.21 Lățime globală	b1	mm	520
4.22 Dimensiuni furcă - grosime	s	mm	60
4.22 Dimensiuni furcă - Lățime	e	mm	155
4.22 Dimensiuni furcă - Lungime	l	mm	1150
4.25 Distanța între furci	b5	mm	520
4.32 Gardă la sol și mijloc ampatament	m2	mm	25
4.34 Lățime culoar	Ast	mm	1844
4.35 Rază de virare	Wa	mm	1369

Performante

5.2 Viteză de ridicare, încărcat	strokes		9
5.2 Viteză de ridicare, descărcat	strokes		9

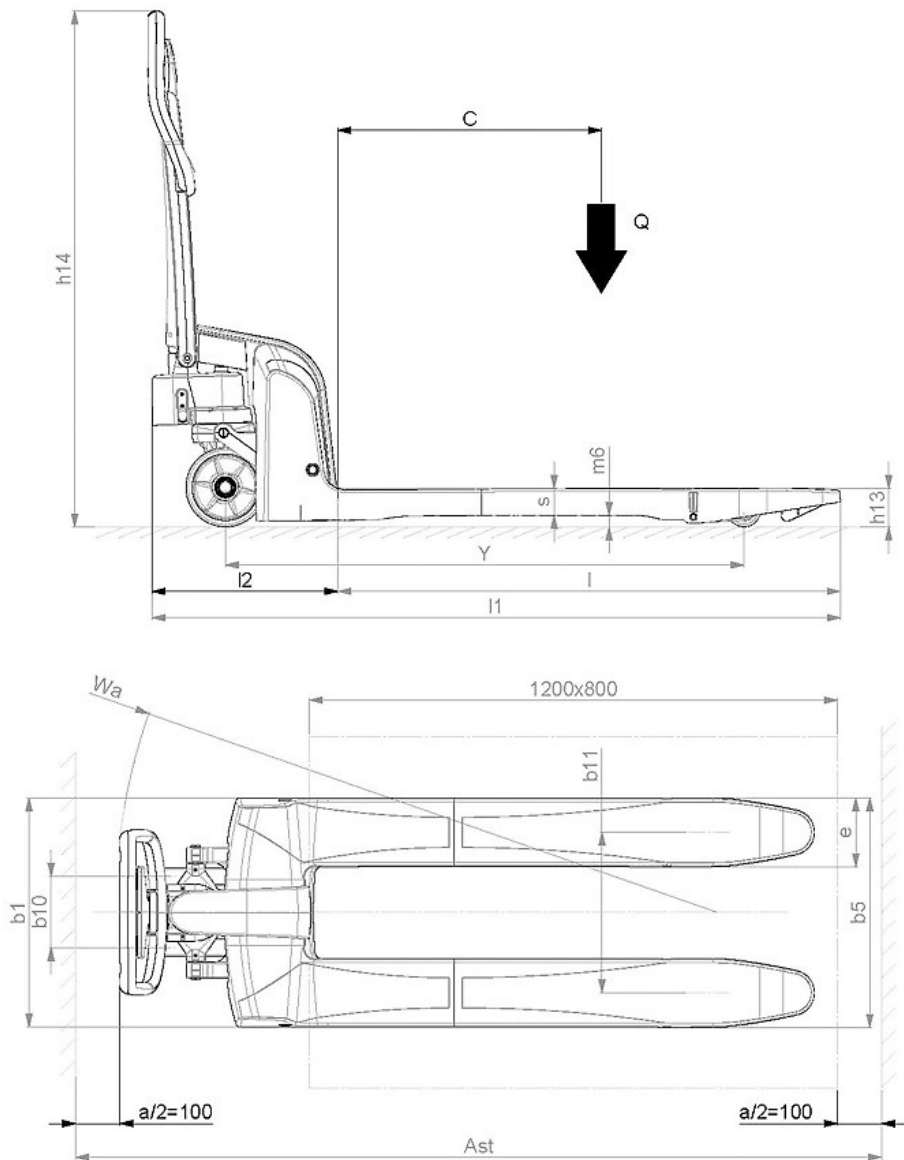

The information is aligned with the Data file at the time of download. Printed on 01/10/2017 (ID 532)

©2017 | PR INDUSTRIAL s.r.l. | All rights reserved | Image shown may not reflect actual package. Specifications subject to change without notice

